



YAKUT KAZAN



AIR & COMPRESSOR TANKS



Lloyd's Register



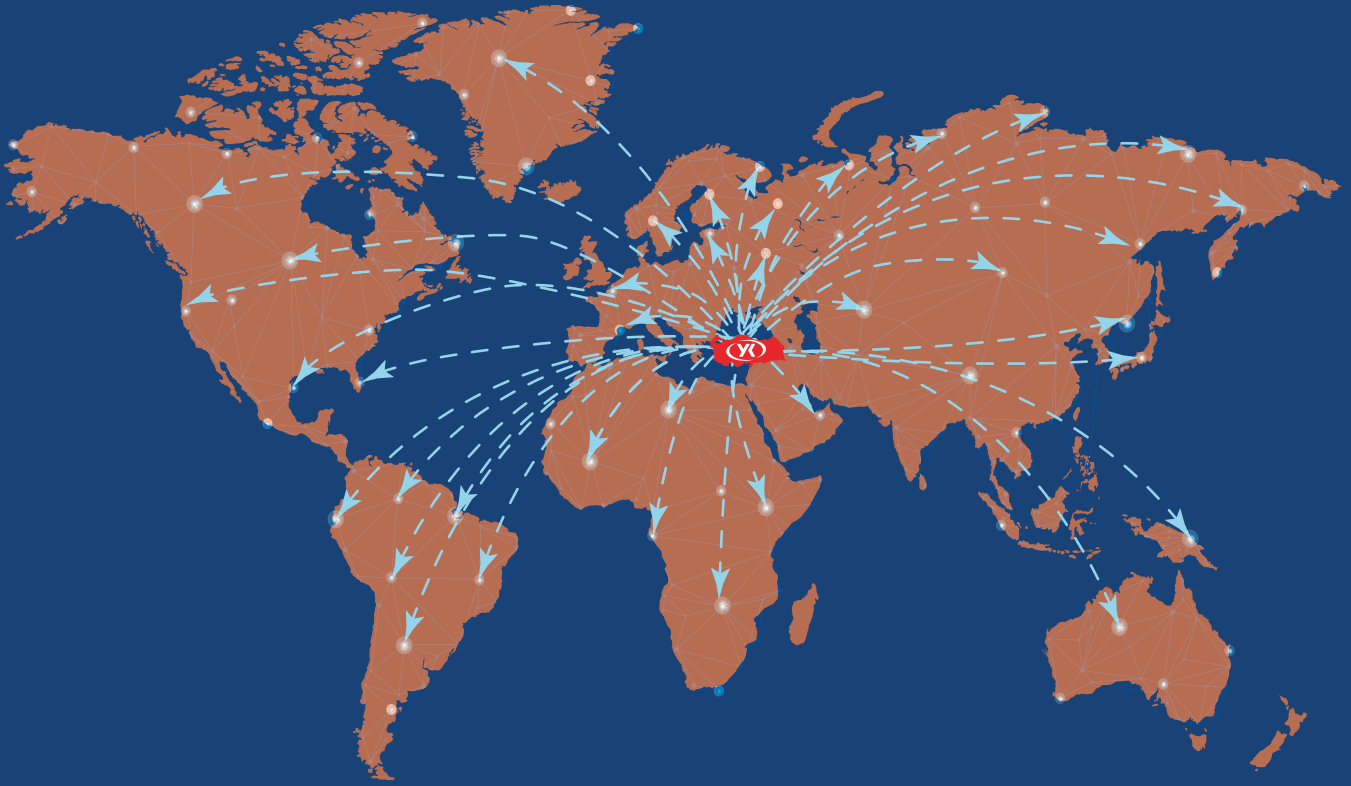

Our Export Countries



Our Certificates





About Us

Yakut Kazan, founded in 1998, has taken an important place in the sector by prioritizing high quality and customer satisfaction since the day it was founded. The company, which constantly follows technological developments, realizes its world-class productions with its expert and experienced staff.

Expert Team and Wide Product Range

Yakut Kazan; offers a wide range of products for the needs of different sectors thanks to its expert team of experienced engineers and technicians. It manufactures in many areas such as pressure tanks, air tanks, separator tanks, fuel storage tanks, chemical storage tanks, stainless and galvanized coated tanks.

Products include boiler tanks, vacuum tanks, cooling (ammonia) tanks and special productions.

International Quality Standards and Certificates

Production in World Standards: Yakut Kazan air tanks are manufactured in accordance with internationally accepted quality standards such as **ASME, DIN, CE, TÜV, BREAU VERITAS, RINA, DNV GL, EAC, CLASSNK, ABS, CCS, LLOYD'S REGISTER, TÜRK LOYDU, RINA, RUSSIAN MARITIME REGISTER SHIPPING, TÜV CERT, TÜV SÜD, GOST, TÜV AUSTRIA**. In this way, the safety and durability of the products are ensured at the highest level. In addition, it proves its quality in production processes with the ISO 9001 Quality Management System Certificate.



Mission

To be a pioneer in the sector by offering sustainable and innovative solutions for the special needs of our customers with our wide range of products produced in international standards.



Vision

A leading company that pushes the boundaries in industrial tank technologies for a sustainable future, offering globally recognized, innovative and environmentally friendly solutions.

*“Indulge In
Luxury That
Defines
Elegance.”*



Yakut Kazan Production Tracking and Monitoring System

Material Information:

All materials used in the production of the product (sheet metal, welding wire, paint and raw materials, etc.) batch numbers, supplier information, entry dates and certificates are recorded in the system.

Production Stages:

Information such as which stages the product goes through (cutting, bending, welding, assembly, testing, etc.), who the personnel in charge of the production process are, and the start and end dates of the stages are entered into the system.



Test and Control Information:

Information such as which stages the product goes through (cutting, bending, welding, assembly, testing, etc.), who the personnel in charge of the production process are, and the start and end dates of the stages are entered into the system.

Shipment Information:

Information such as when the product was shipped, recipient information, delivery note number, transportation method and delivery date are recorded in the system. It can be checked that the product was delivered to the customer on time and completely.



OUR PRODUCTS

- Compressed Air Tanks
- Air & Oil Separator Tanks
- Fuel and Storage Tanks
- Stainless Steel and Galvanized Coated Tanks
- Vacuum Tanks
- Cooling (Ammonia) Tanks
- Nitrogen & Oxygen Tanks
- Specially Manufactured Tanks

Compressed Air Tanks



QUALITY AND RELIABLE COMPRESSED AIR TANKS

Yakut Kazan air tanks, with its long years of experience in the sector, offers its customers high quality, reliable and durable products. Air tanks produced in accordance with international standards, certify their reliability with the certificates they have.

Yakut Kazan is a pioneer in the sector with its specially designed and high-quality air tanks that add value to its customers' production processes. Thanks to meticulously controlled production processes and compliance with international standards, the tanks offer long-lasting and durable use, maximizing customer satisfaction. Air tanks designed by an experienced engineering team offer customizable industrial solutions for the specific needs of different sectors.

Features of Yakut Kazan Compressed Air Tanks

**STRONG
DURABLE
AND
RELIABLE**

High Quality and Durability: Yakut Kazan uses the highest quality materials in the production of air tanks and follows a meticulous production process. Thanks to quality control processes, long-lasting and reliable products are produced.

Türkiye Mechanical Engineers Eligibility: Yakut Kazan meticulously complies with the directives of the Chamber of Mechanical Engineers of Türkiye (TMMOB) and relevant standards in tank production. In this way, the safety, durability and efficiency of the tanks produced are ensured at the highest level.

Durability and Aesthetic Appearance with Electrostatic Powder Paint: The outer surfaces of the tanks are coated with electrostatic powder paint, providing better adhesion of the paint to the surface and thus providing high resistance against corrosion.



Manufacturing According to the Desired Pressure: Specially designed tanks suitable for different volume and pressure ranges can be manufactured according to customer needs.

CE Certificate: All Yakut Kazan air tanks have the CE certificate, which shows that they comply with the high safety standards determined by the European Union.

Production in World Standards



Perfect Production in Compressed Air Tanks

Material Options

- Carbon Steel – P265 GH, P355GH, P355 NH, P355 NL1/2 Steel
- Stainless Steel – AISI304, AISI304L, AISI316, AISI316Ti
- Hot Dip Galvanized Steel

Wide Range of Products

- Air Tanks
- Vacuum Tanks
- Vertical Tanks
- Horizontal Tanks
- Compressed Air Tanks
- Special Tanks
- Nitrogen Tanks
- Up to 4000mm at standard pressures of 11, 16, 25, 40, 50, 60 bar

***Professional Solutions
in Compressed
Air Tanks***



1 LT. & 50,000 LT. COMPRESSED AIR TANKS PRODUCTION

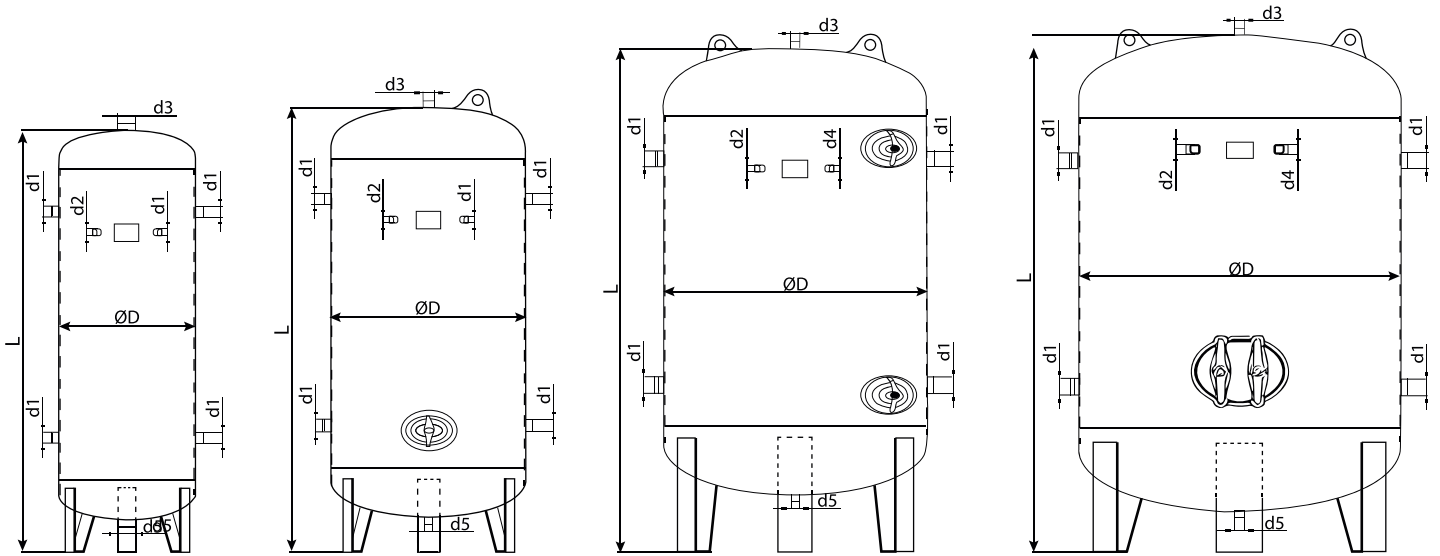

Dimension Table

VERTICAL TYPE								
Volume	"Diameter ØD mm"	"Length L mm"	"Working Pressure"	d1	d2	d3	d4	d5
100 lt	323	1.450	11 Bar	1"	1/2"	2"	1/2"	2"
			16 Bar					
			40 Bar					
200 lt	480	1.550	11 Bar	1"	1/2"	2"	1/2"	2"
			16 Bar					
			40 Bar					
300 lt	480	1.860	11 Bar	1"	1/2"	2"	1/2"	2"
			16 Bar					
			40 Bar					
500 lt	600	2.110	11 Bar	1 1/4"	1/2"	2"	1/2"	2"
			16 Bar					
			40 Bar					
"900 lt 1.000 lt"	850	2.210	11 Bar	1 1/2"	1/2"	1"	1/2"	3/4"
			16 Bar					
			40 Bar					
1.500 lt	1000	2.290	11 Bar	1 1/2"	1/2"	1"	1/2"	3/4"
			16 Bar					
			40 Bar					
2.000 lt	1150	2.400	11 Bar	2"	1/2"	1"	1/2"	3/4"
			16 Bar					
			40 Bar					
3.000 lt	1400	2.560	11 Bar	2"	1/2"	1"	1/2"	3/4"
			16 Bar					
3.000 lt	1150	3.300	40 Bar	2"	1/2"	1"	1/2"	3/4"
4.000 lt	1600	2.700	11 Bar	DN80	1/2"	1 1/2"	1"	1"
			16 Bar					
5.000 lt	1600	3.200	11 Bar	DN80	1/2"	1 1/2"	1"	1"
			16 Bar					
6.000 lt	1600	3.700	11 Bar	DN 80	1/2"	2"	1"	1"
			16 Bar					
8.000 lt	1600	4.670	11 Bar	DN100	1/2"	2"	1"	1"
			16 Bar					
10.000 lt	1900	4.370	11 Bar	DN100	1/2"	2"	1"	1"
			16 Bar					

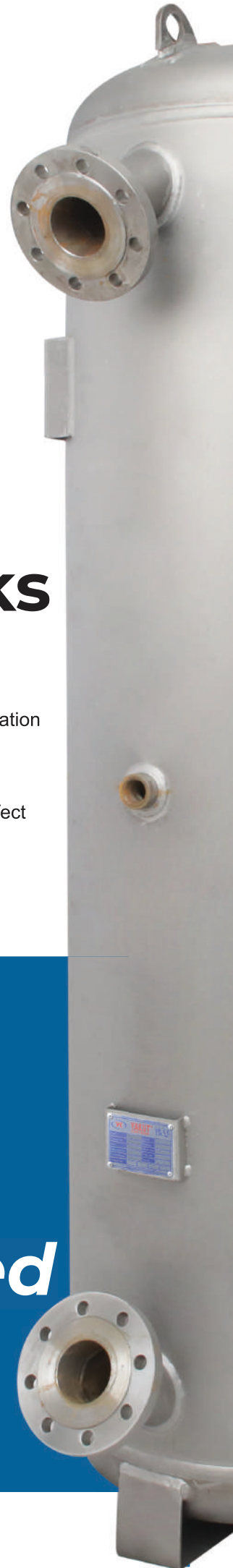

Air & Oil Separator Tanks

Yakut Kazan specializes in separator tanks and offers sustainable solutions for special projects.

Separator tanks, which are an indispensable part of industrial processes, provide effective separation of liquids of different densities or solid-liquid mixtures.

Yakut Kazan separator tanks increase the efficiency of production processes and significantly affect product quality.

Suitable solutions are offered for separation processes in different sectors with projects specially designed according to the needs of customers.



***Sustainable
Solutions,
Uninterrupted
Reliability!***

Fuel and Storage Tanks

Fuel and storage tanks, which have become an indispensable part of industrial series and daily life, must have the highest separation in terms of safety and durability.



Meet Reliability & Quality!

Volume Range

- 100 LT to 100,000 LT or 50 m³ - 5,000 m³
- Horizontal and Vertical D 4000 mm and L 30000 mm

Product Range

- Above Ground Fuel Tanks
- Under Ground Fuel Tanks
- Vertical Fuel Tank



Fuel and Storage Tanks

REALIZE THE POWER OF
ENGINEERING WITH YAKUT KAZAN!

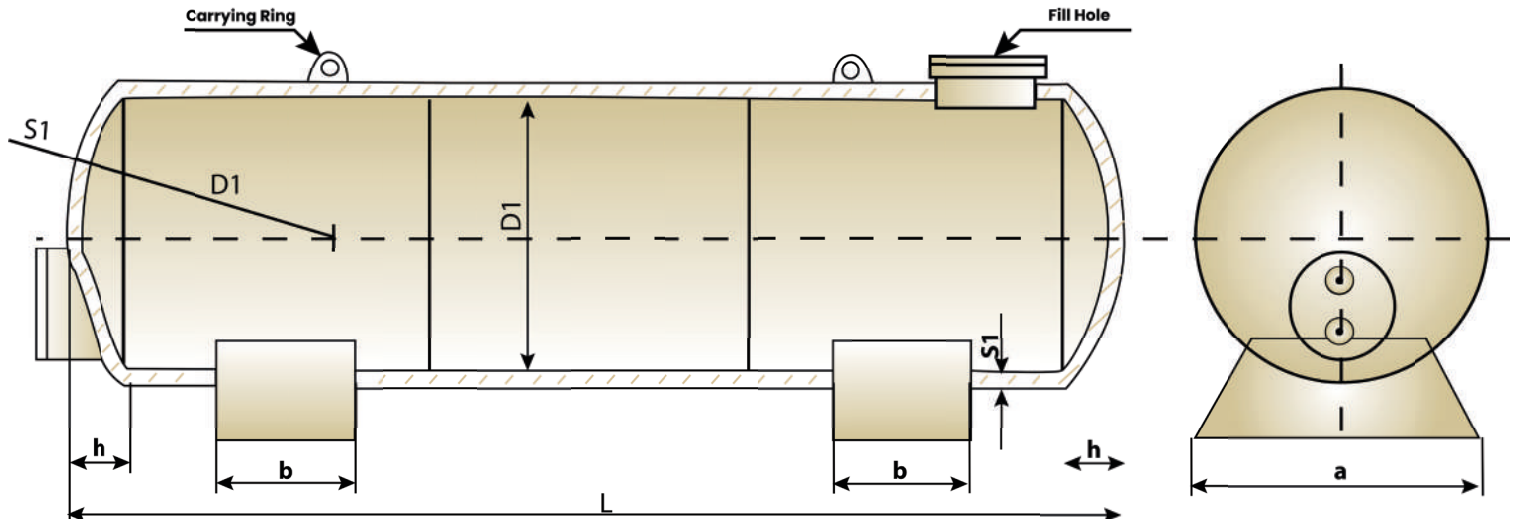

Volume (m ³)	1	3	5	7	10	13	16	20	25	30	40	50	60	80	100
Outer Diameter D1	1000	1250	1600				2000				2500		2900		
Total Length L	1510	2750	2820	3740	5350	6960	8570	6960	8510	10120	8800	10800	12800	12750	15950
Camber Height h	180	220	260				320				400		450		
Sheet Thickness S1	5					6					7		9		
Filling Hole Inner Diameter D2	500					600									
Number of Bearing Coils	1					2									
Thank Stand b	350			525			600			950			1350		
Dimensions a	1400					1600					2000		2400		
Weight (kg)	500	750	890	1030	1350	1700	2000	2550	3000	3600	4600	5500	6500	9750	11750

Tank Manhole Dimensions

INNER DIAMETER D2	C1 DISTANCE (mm)	SHEET DISTANCE S2	DIAMETER OF FLANGE DAMPER D3	HOLE AXIS DIAMETER K	CAP SCREW HOLE DIAMETER	THICKNESS OF FLANGE DAMPER S2	CAP SCREW	
							DIMENSION BASED ON TS80	NUMBER
500	450	5	620	560		16		28
600	350	5	720	680	18	16	M16	32
800	400	5	830	880		20		44



Stainless Steel & Galvanized Coated Tanks

Meeting Point of Quality and Reliability

Yakut Kazan offers special products made of high quality stainless steels such as AISI 304L, 316L, 316Ti and 310 for the needs of different sectors. Stainless steel and galvanized tanks are preferred in many sectors due to their high resistance to corrosion, durability and hygienic features.

As Yakut Kazan, we are proud to be one of the leading companies in the sector in stainless steel and galvanized tank production.



Vacuum Tanks

Perfect Vacuum, Perfect Solution...

As Yakut Kazan, we offer reliable and efficient solutions to our customers with vacuum tanks that we produce at high quality standards. Strengthen your production with corrosion-resistant, long-lasting vacuum tanks!



Cooling (Ammonia) Tanks

Cooling Systems are Safe with Yakut Kazan!

Yakut Kazan has gained trust in the market with its modern production product professional team, cooling (ammonia) tank wide range of solutions and high quality standards.

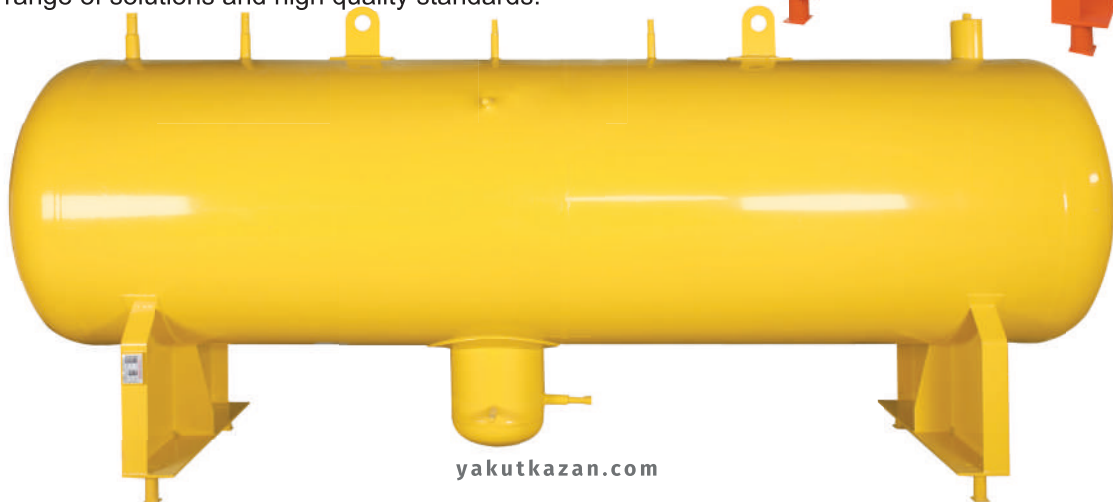

Nitrogen & Oxygen Tanks

Yakut Kazan manufactures high quality tanks for nitrogen and oxygen generators. The tanks are designed to ensure the safe storage of gases such as nitrogen and oxygen. Factors such as leak-proofness, bar pressure resistance and fire safety are taken into consideration.

Yakut Kazan can manufacture nitrogen and oxygen tanks in different sizes and capacities according to the needs of its customers.



Custom Design Manufacture

Pressure Tank Production with Customer-Specific Solutions



Yakut Kazan is a pioneer in the sector by carrying out special manufacturing in line with customer demands and the needs of the process processes. It offers effective and innovative solutions in the field of special pressure tank production with its design team consisting of expert and competent engineers.



Pressure tanks to be manufactured in special design programs in accordance with international standards by Yakut Kazan design engineers are designed and transferred to the production process. The production process is carried out with a quality and reliability-oriented approach, ensuring that the most suitable solutions are offered to the needs of the customers.

Engineering Support and Design Process



Yakut Kazan's experienced design engineers develop special design projects in line with customer requests. They are designed and manufactured using special design programs in accordance with international standards according to customer needs. Thanks to our modern production facility and experienced team, each product fully meets the customer's special needs.

Warranty and Service

Yakut Kazan, as a company that always prioritizes customer satisfaction, attaches great importance to after-sales services. It has in the quality of its products with the confidence. It provides complete assurance to its customers by offering a one-to-one replacement service in case of any manufacturing or workmanship error.

Fast and Effective Solution



Yakut Kazan evaluates the demands received under warranty as soon as possible and offers fast and effective solutions.



Reliable Solutions for the Defense Industry in Difficult Conditions



Yakut Kazan has become a reliable partner in the sector with its high-quality tanks, storage and industrial solutions for the defense industry. The products offered by the company to the defense industry are designed and manufactured to provide superior performance even under the most difficult conditions.

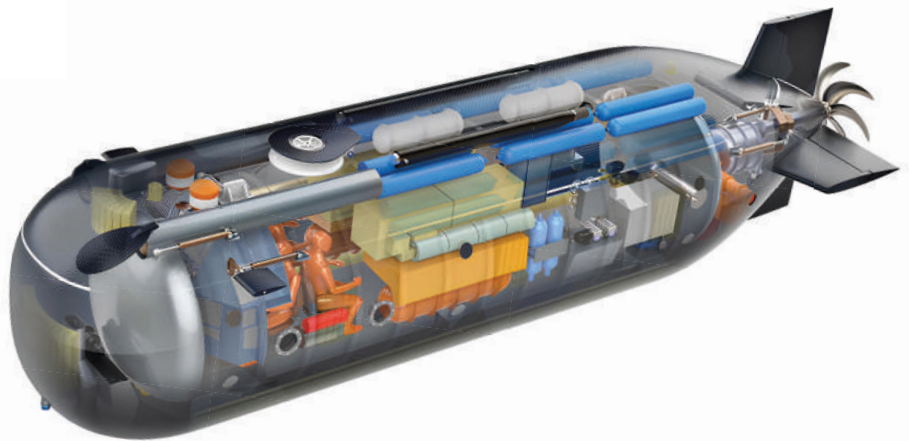

We Add Power to the Defense of the Future...

Yakut Kazan manufactures its products from quality materials and puts each product through rigorous tests one by one and has international certificates.



YAKUT KAZAN



Contact Information



PHONE

+90 212 623 18 74



E-MAIL

info@yakutkazan.com

www.yakutkazan.com

www.yakuttank.com



ADDRESS:

Yassiören Mahallesi Akpınar Sanayi Sitesi Mediha

Sokak No:8 Arnavutköy - İstanbul

